

MODEL: NH-400PW-F(L)



PE : 1.2

Frecuencia : 60Hz

DIÁMETRO IMPULSOR : 77 mm

	BOMBA				MOTOR
	Capacidad en descarga	Presión en descarga	CDT	Eficiencia Bomba	Potencia requerida
	L/MIN	M	M	%	kW
1	0	10.0	10.0	0	0.130
2	135	7.0	7.0	55.7	0.270
3	170	5.5	5.5	52.7	0.320
4	215	3.0	3.0	46.3	0.350
5	--	--	--	--	--

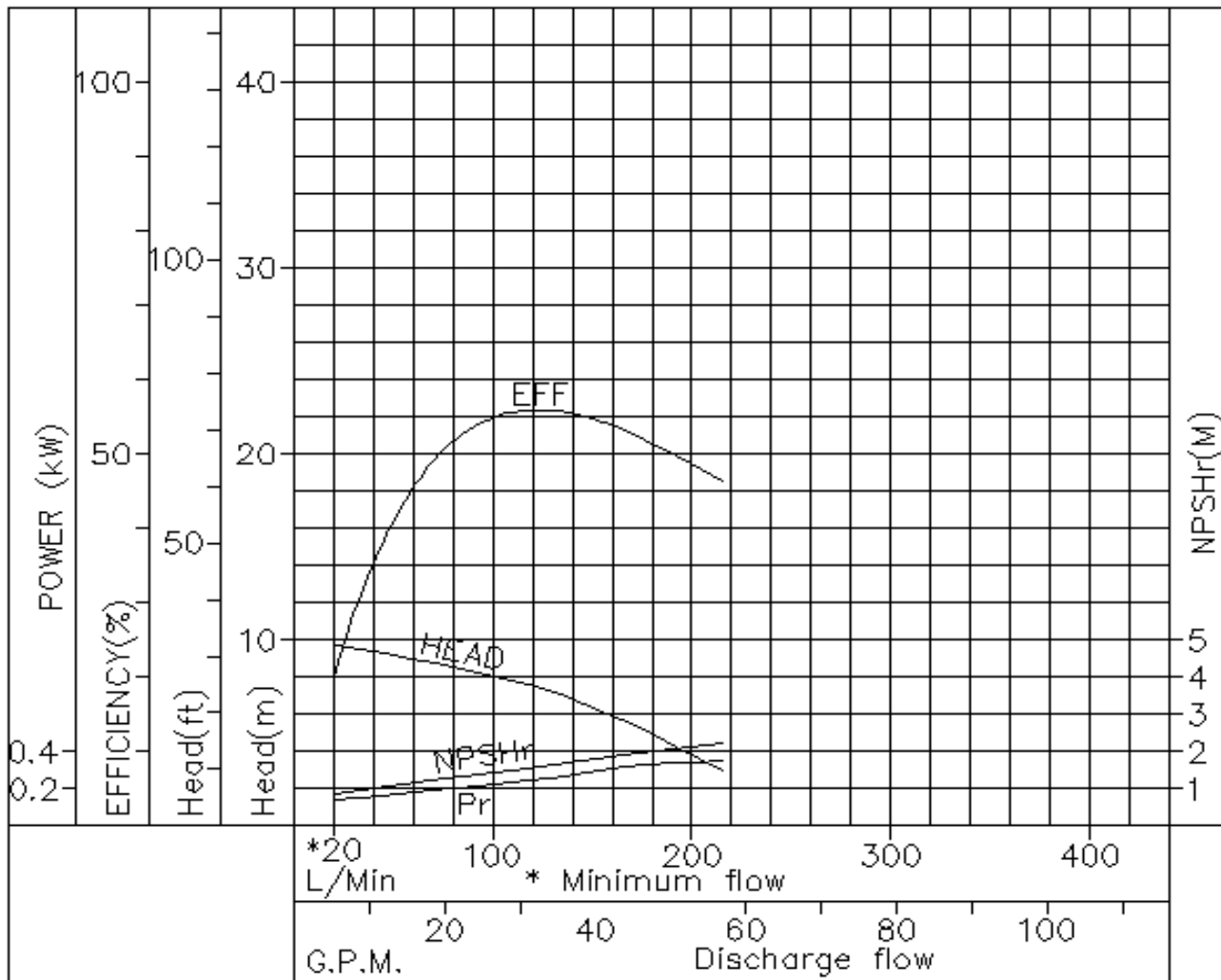

- NOTE :
- | | |
|-------------------------------|-------------------|
| 1. Punto de operación nominal | 8.0 m a 110 l/min |
| 2. Velocidad | 3440 R.P.M. |
| 3. Rango de temperatura | 0 - 70 °C ETFE. |
| 4. Potencia requerida | 0.37 kW |

DIMENSIONES

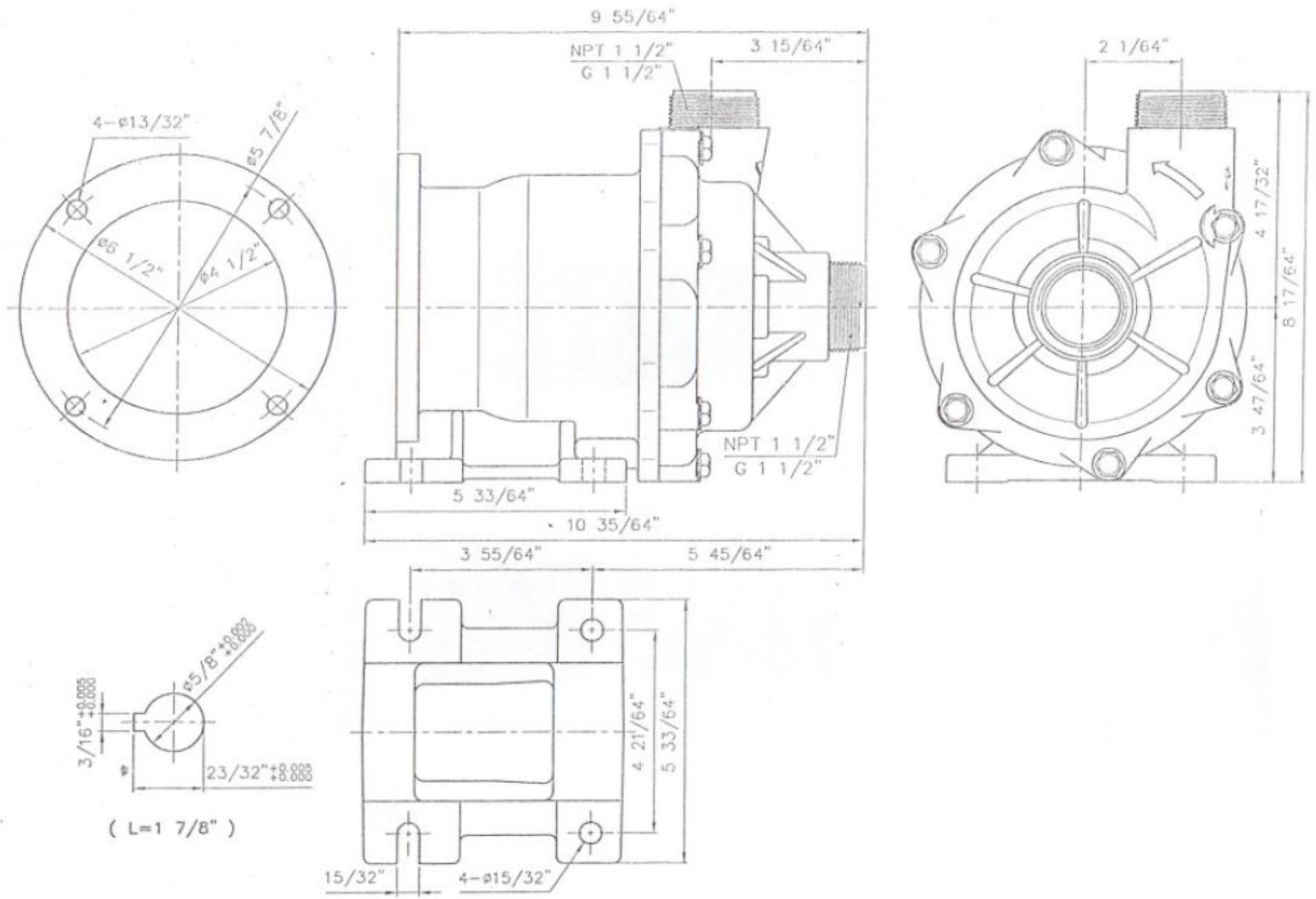

PRODUCTOS MAV, S.A. DE C.V. / G-PUMPS