

MODEL: NH-401PW-F(L)



PE : 1.2

Frecuencia : 60Hz

DIÁMETRO IMPULSOR : 93 mm

BOMBA				MOTOR
Capacidad en descarga	Presión en descarga	CDT	Eficiencia Bomba	Potencia requerida
L/MIN	M	M	%	kW
1	0	14.5	0	0.450
2	110	12.0	40.2	0.590
3	180	9.5	48.0	0.610
4	235	6.0	40.2	0.620
5	--	--	--	--

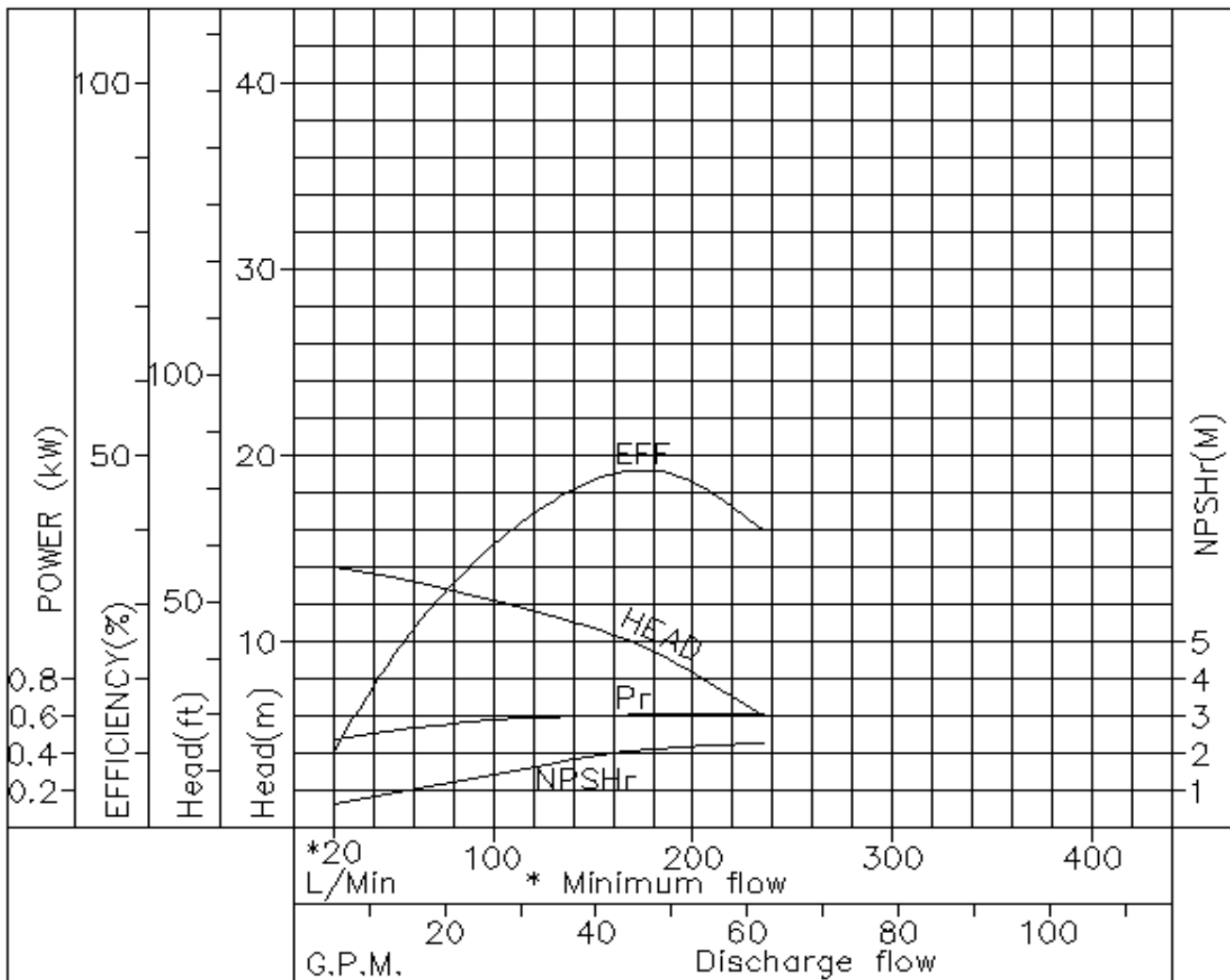

- NOTE :
- | | |
|-------------------------------|-------------------|
| 1. Punto de operación nominal | 9.5 m a 180 l/min |
| 2. Velocidad | 3440 R.P.M. |
| 3. Rango de temperatura | 0 - 70 °C ETFE. |
| 4. Potencia requerida | 0.75 kW |

DIMENSIONES

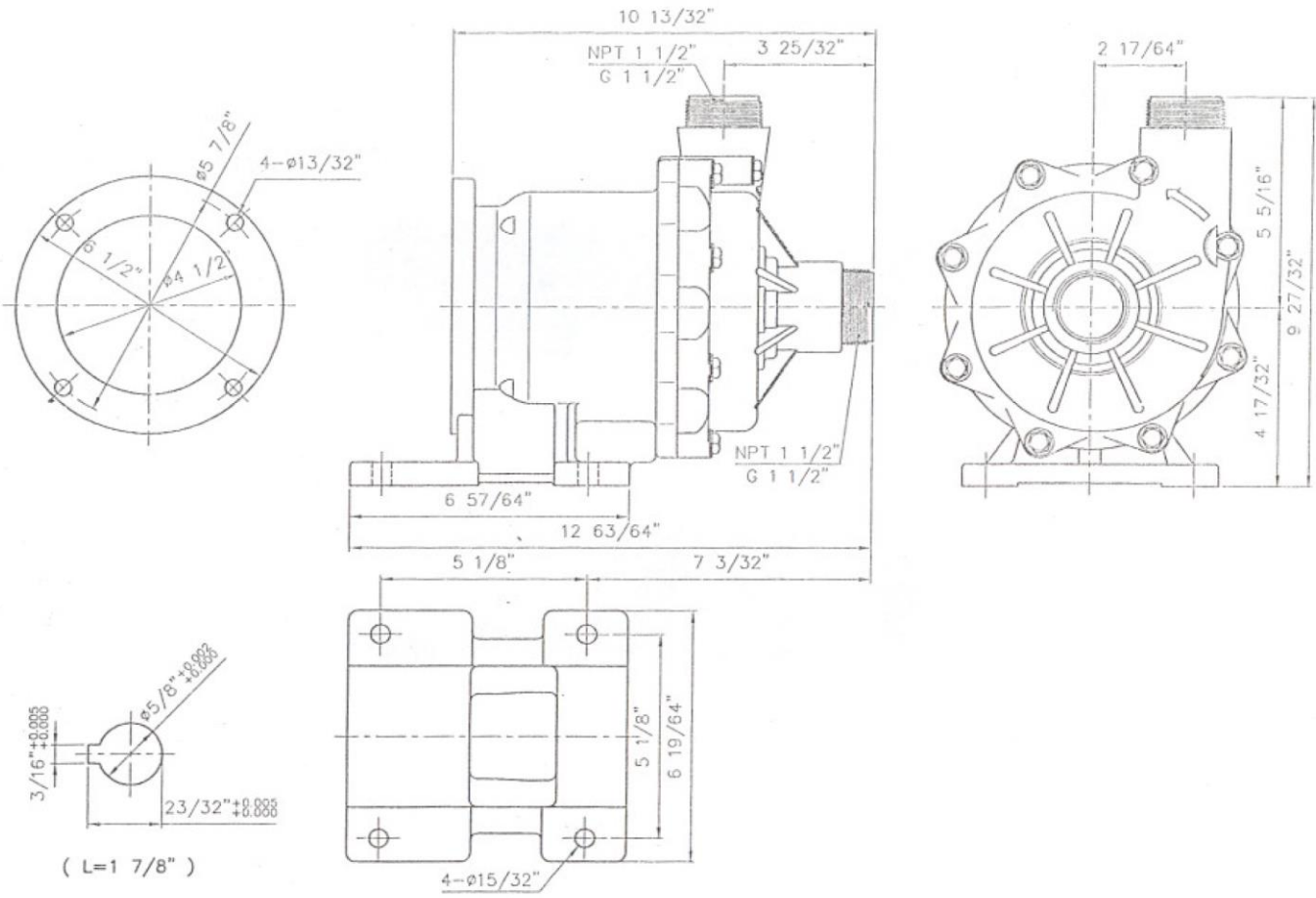

PRODUCTOS MAV, S.A. DE C.V. / G-PUMPS