

# MODEL: NH-402PW-F(L)

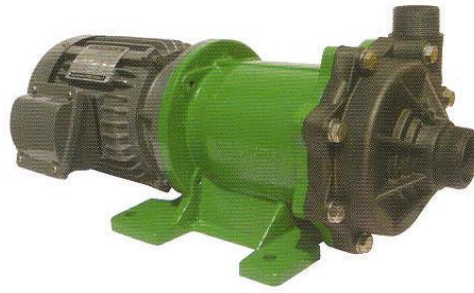

PE : 1.2

Frecuencia : 60Hz

DIÁMETRO IMPULSOR : 108 mm

	BOMBA				MOTOR
	Capacidad en descarga	Presión en descarga	CDT	Eficiencia Bomba	Potencia requerida
	L/MIN	M	M	%	kW
1	0	23.2	23.2	0	0.850
2	260	15.5	15.5	52.6	1.250
3	360	7.6	7.6	35.1	1.270
4	440	3.7	3.7	22.9	1.160
5	--	--	--	--	--

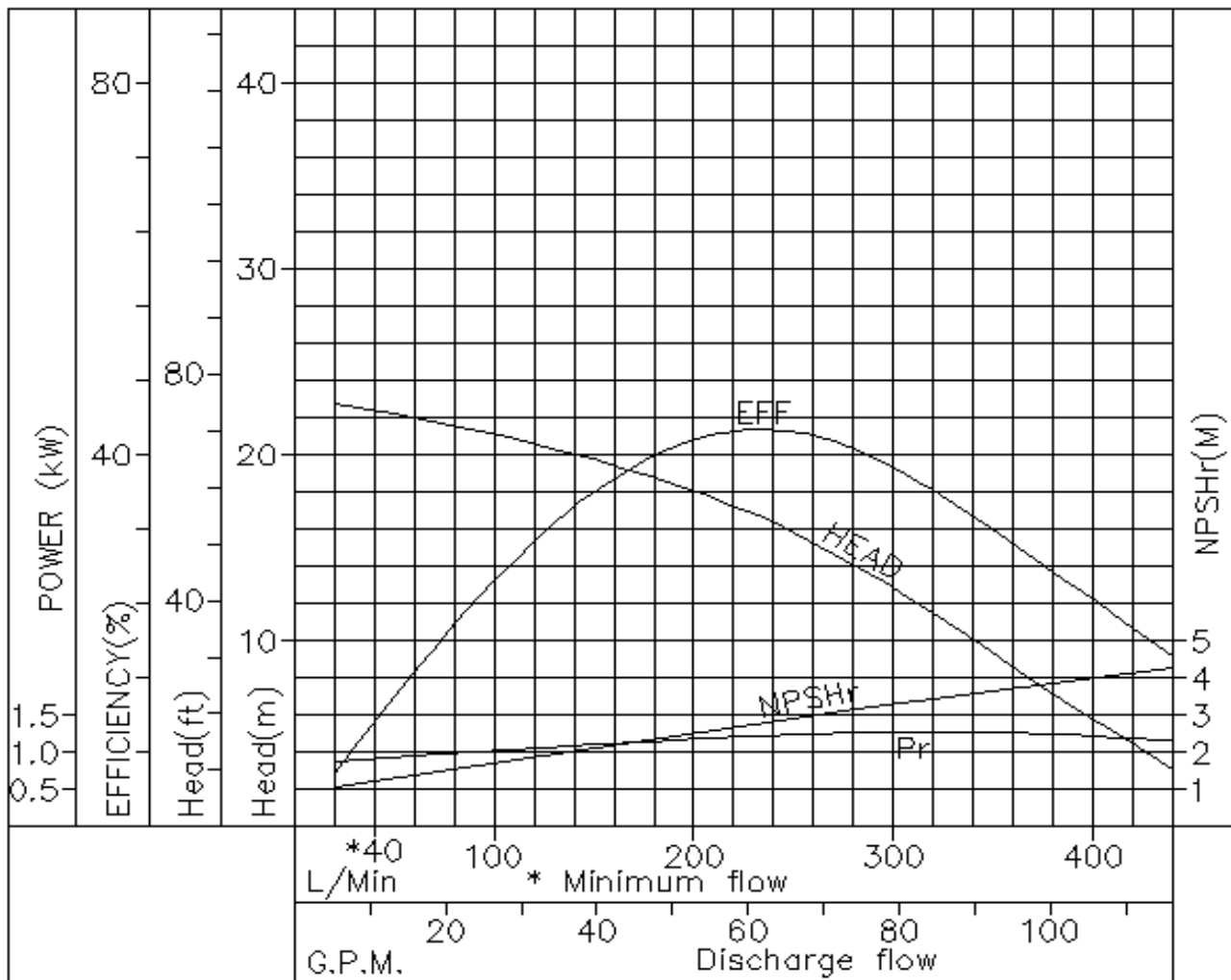

- NOTE :
- |                               |                    |
|-------------------------------|--------------------|
| 1. Punto de operación nominal | 15.5 m a 260 l/min |
| 2. Velocidad                  | 3440 R.P.M.        |
| 3. Rango de temperatura       | 0 - 70 °C ETFE.    |
| 4. Potencia requerida         | 1.5 kW             |

**DIMENSIONES**

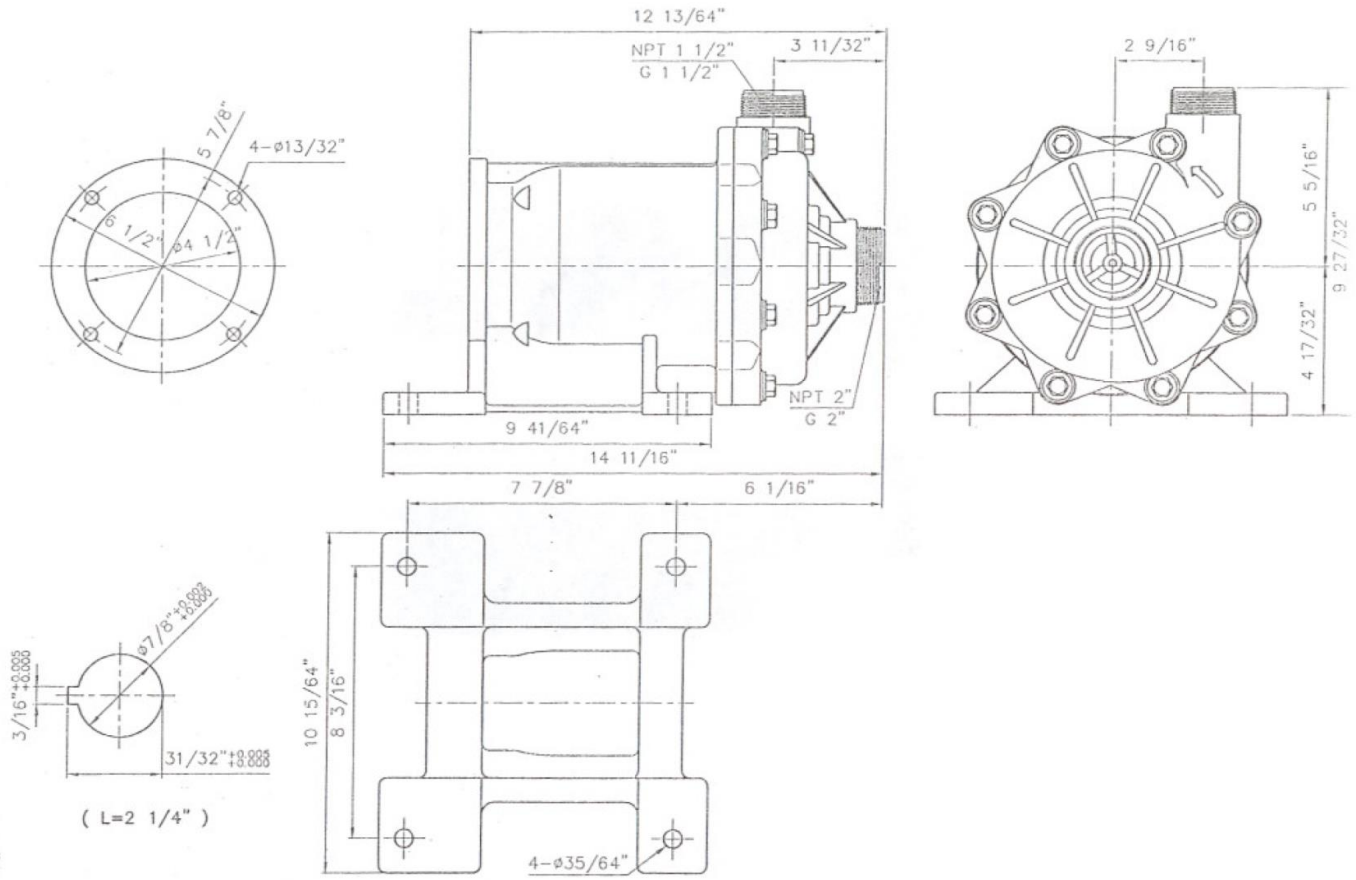

**PRODUCTOS MAV, S.A. DE C.V. / G-PUMPS**