

MODEL: NH-403PW-F(L)



PE : 1.2

Frecuencia : 60Hz

DIÁMETRO IMPULSOR : 111 mm

	BOMBA				MOTOR
	Capacidad en descarga	Presión en descarga	CDT	Eficiencia Bomba	Potencia requerida
	L/MIN	M	M	%	kW
1	0	26.0	26.0	0	1.20
2	330	15.0	15.0	47.5	1.90
3	400	11.5	11.5	42.6	1.76
4	470	3.0	3.0	13.9	1.80
5	--	--	--	--	--

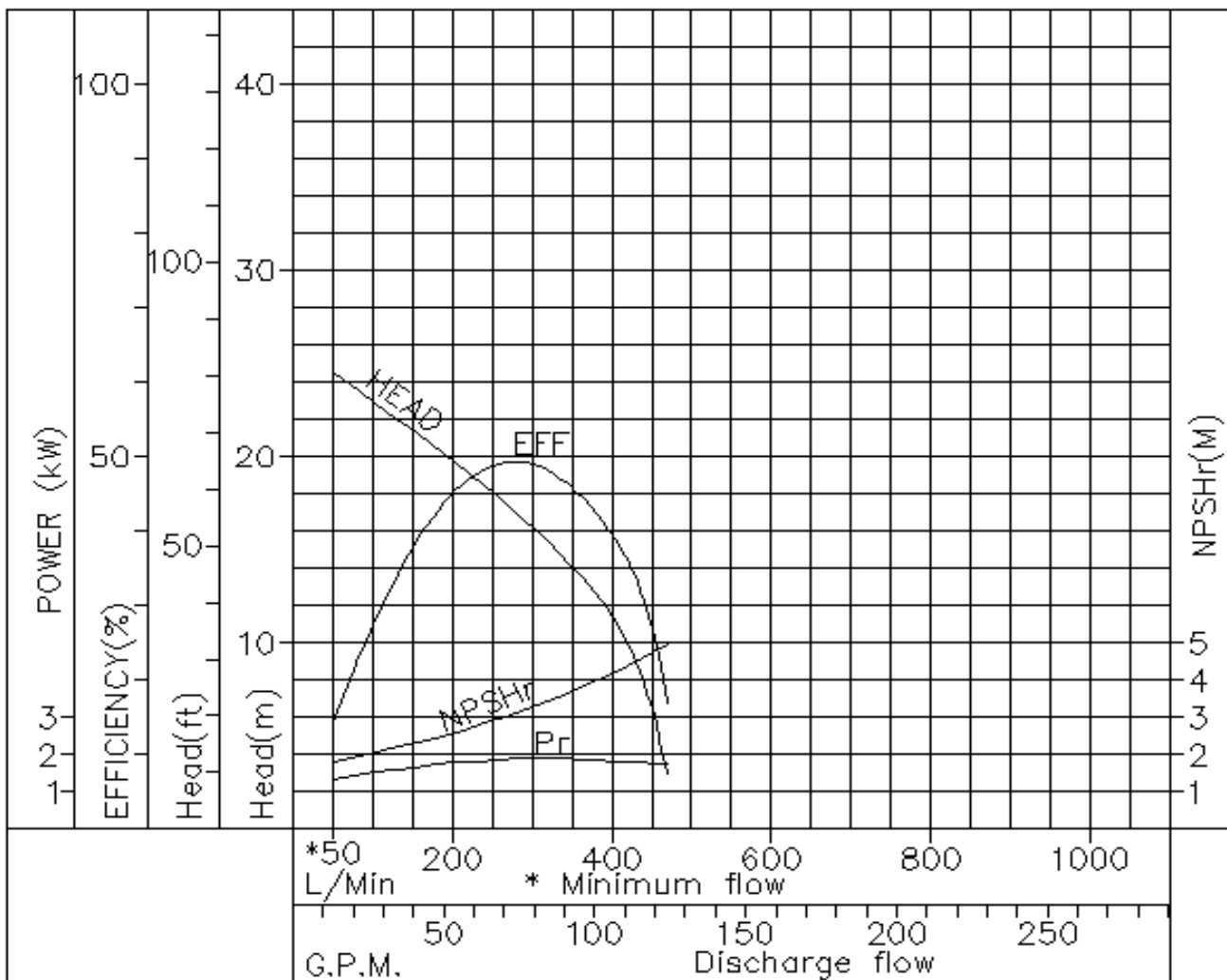

- NOTE :
- | | |
|-------------------------------|--------------------|
| 1. Punto de operación nominal | 15.0 m a 330 l/min |
| 2. Velocidad | 3440 R.P.M. |
| 3. Rango de temperatura | 0 - 70 °C ETFE. |
| 4. Potencia requerida | 2.2 kW |

DIMENSIONES

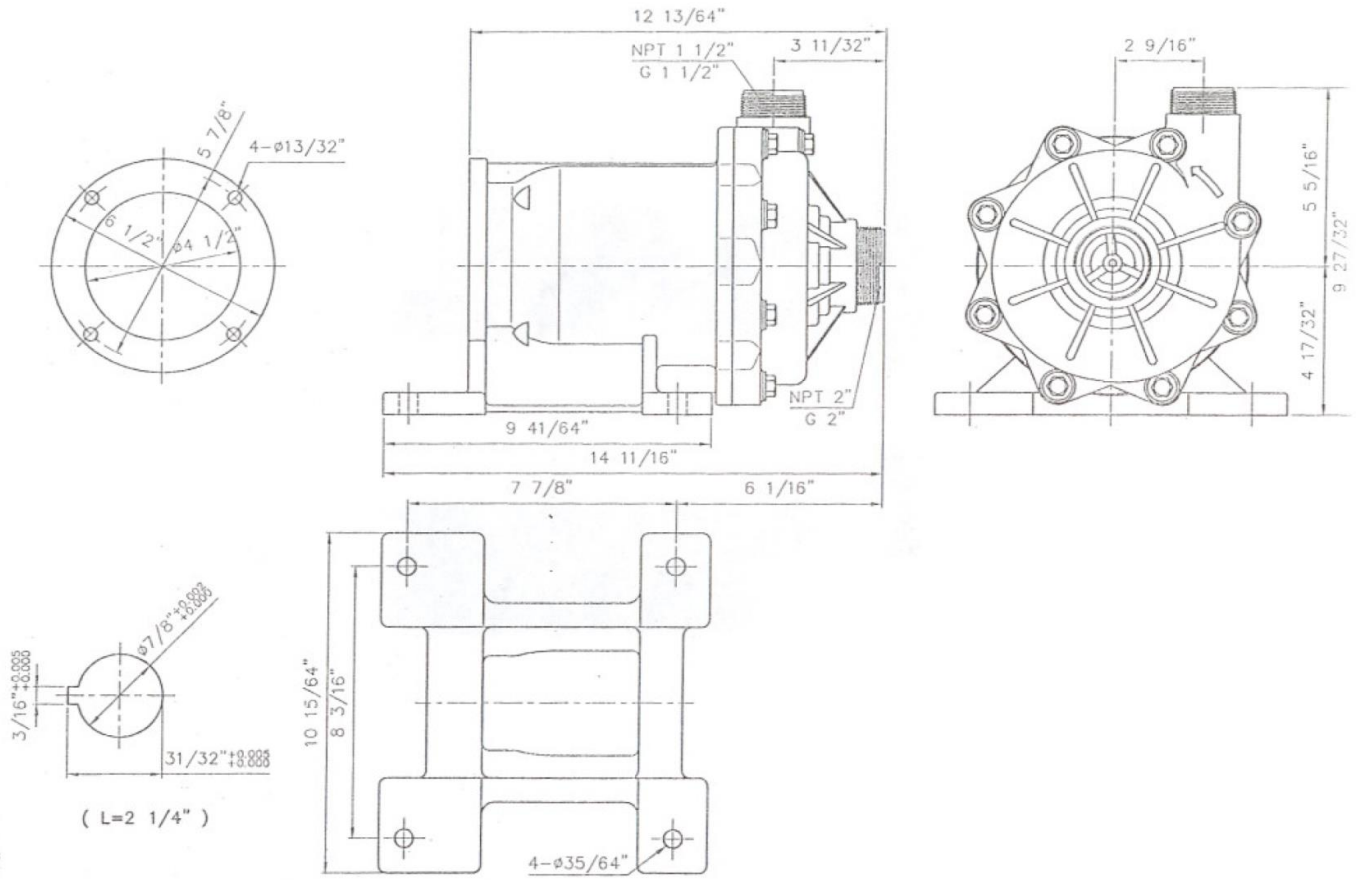

PRODUCTOS MAV, S.A. DE C.V. / G-PUMPS