

MODEL: NH-405PW-F(L)

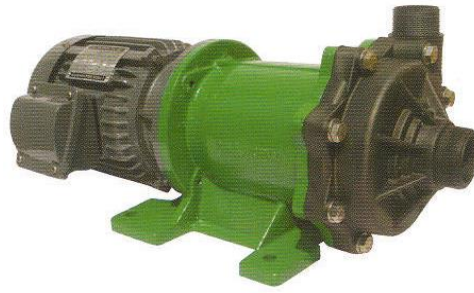

PE : 1.2

Frecuencia : 60Hz

DIÁMETRO IMPULSOR : 133 mm

	BOMBA				MOTOR
	Capacidad en descarga	Presión en descarga	CDT	Eficiencia Bomba	Potencia requerida
	L/MIN	M	M	%	kW
1	0	32.0	32.0	0	1.900
2	200	27.5	27.5	32.6	2.750
3	300	24.0	24.0	37.9	3.100
4	390	20.5	20.5	38.9	3.350
5	550	14.0	14.0	34.9	3.600

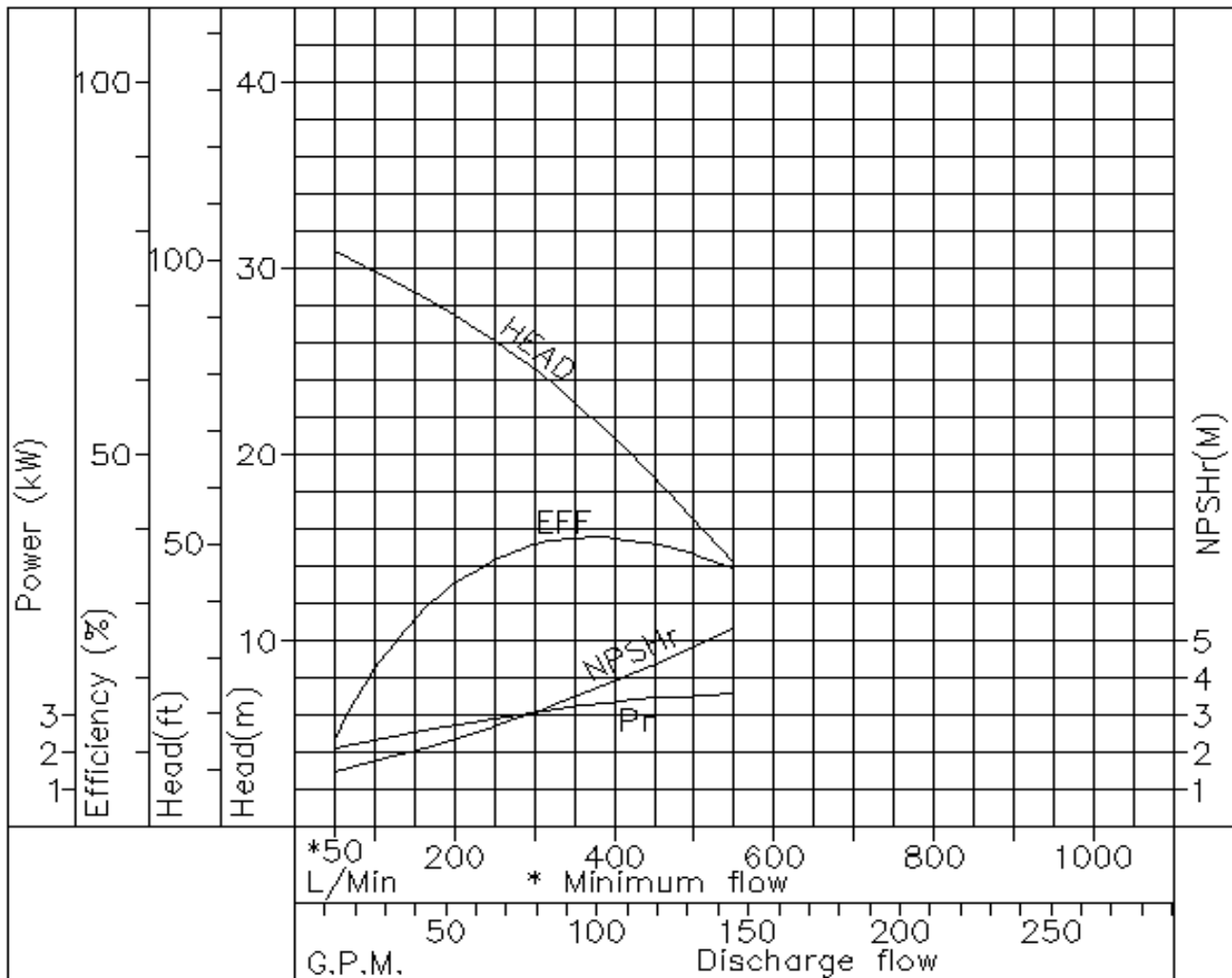

- NOTE :
1. Punto de operación nominal 20.5 m a 390 l/min
 2. Velocidad 3440 R.P.M.
 3. Rango de temperatura 0 - 70 °C ETFE.
 4. Potencia requerida 3.7 kW

DIMENSIONES

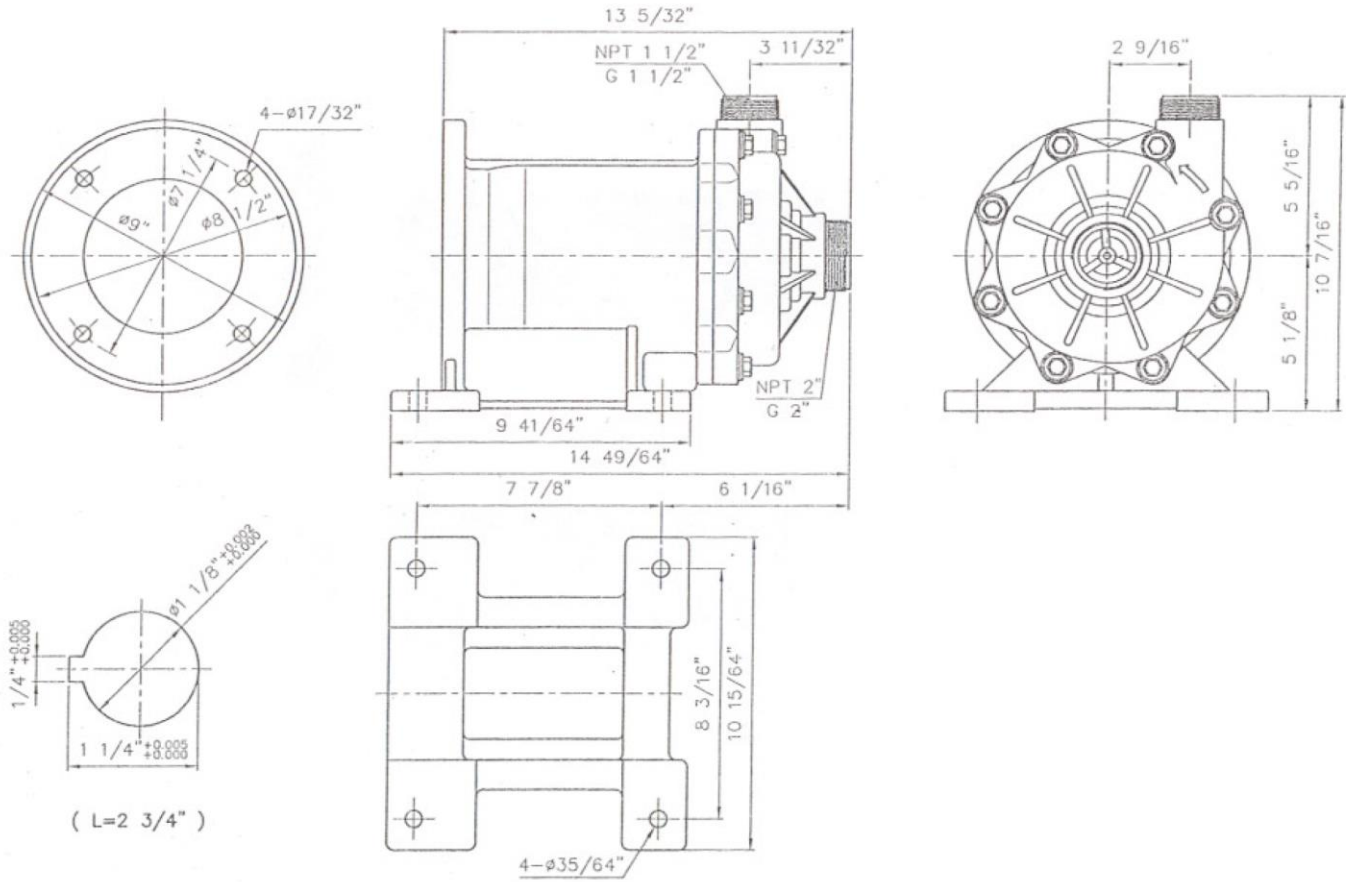

PRODUCTOS MAV, S.A. DE C.V. / G-PUMPS