

# MODEL: NH-400PW(L)



PE : 1.1

Frecuencia : 60Hz

DIÁMETRO IMPULSOR : 80 mm

	BOMBA				MOTOR
	Capacidad en descarga	Presión en descarga	CDT	Eficiencia Bomba	Potencia requerida
	L/MIN	M	M	%	kW
1	0	11.0	11	0	0.230
2	60	10.2	10.2	32.2	0.313
3	120	8.5	8.5	44.9	0.370
4	160	6.7	6.7	46.6	0.375
5	270	2.5	2.5	28.2	0.395

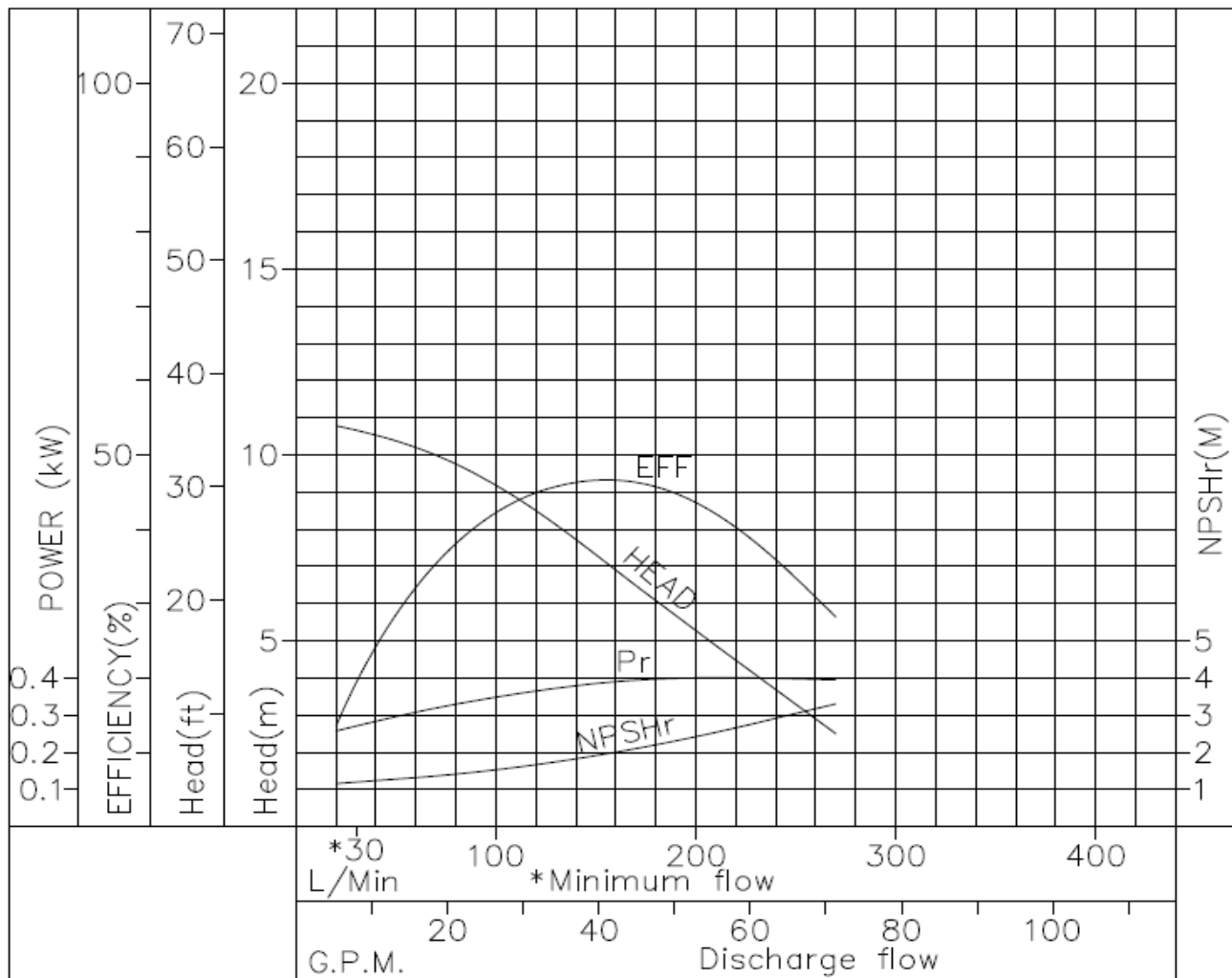

- NOTE :
- |                               |                          |
|-------------------------------|--------------------------|
| 1. Punto de operación nominal | 6.7 m a 160 l/min        |
| 2. Velocidad                  | 3440 R.P.M.              |
| 3. Rango de temperatura       | 0 - 60 °C Polipropileno. |
| 4. Potencia requerida         | 0.37 kW                  |

**DIMENSIONES**

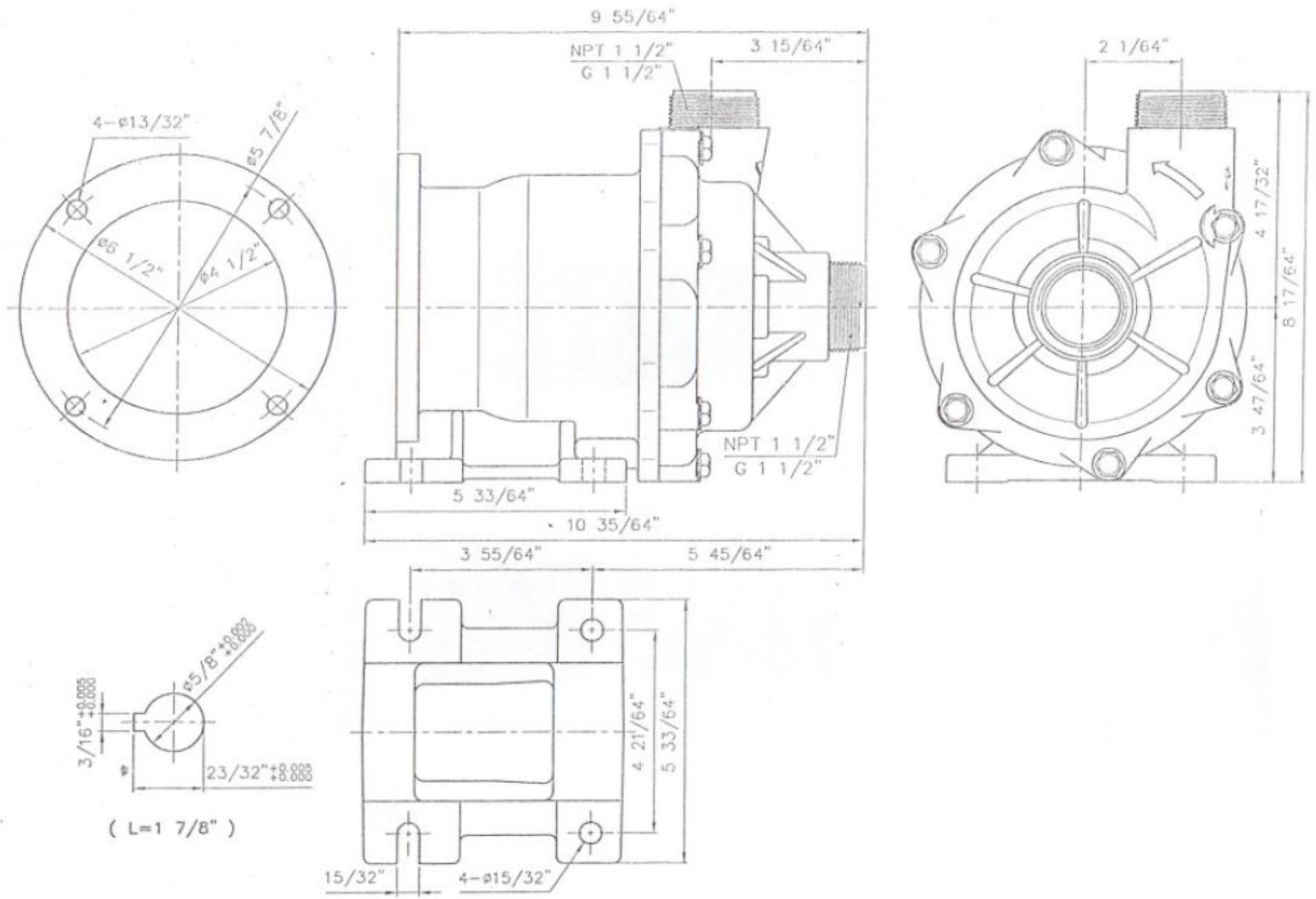

**PRODUCTOS MAV, S.A. DE C.V. / G-PUMPS**