

# MODEL: NH-401PW(L)



PE : 1.1

Frecuencia : 60Hz

DIÁMETRO IMPULSOR : 96 mm

	BOMBA				MOTOR
	Capacidad en descarga	Presión en descarga	CDT	Eficiencia Bomba	Potencia requerida
	L/MIN	M	M	%	kW
1	0	17.6	17.6	0	0.32
2	100	15.2	15.2	42.7	0.58
3	200	13.1	13.1	60.1	0.71
4	300	9.2	9.2	60.0	0.75
5	350	6.1	6.1	46.4	0.75

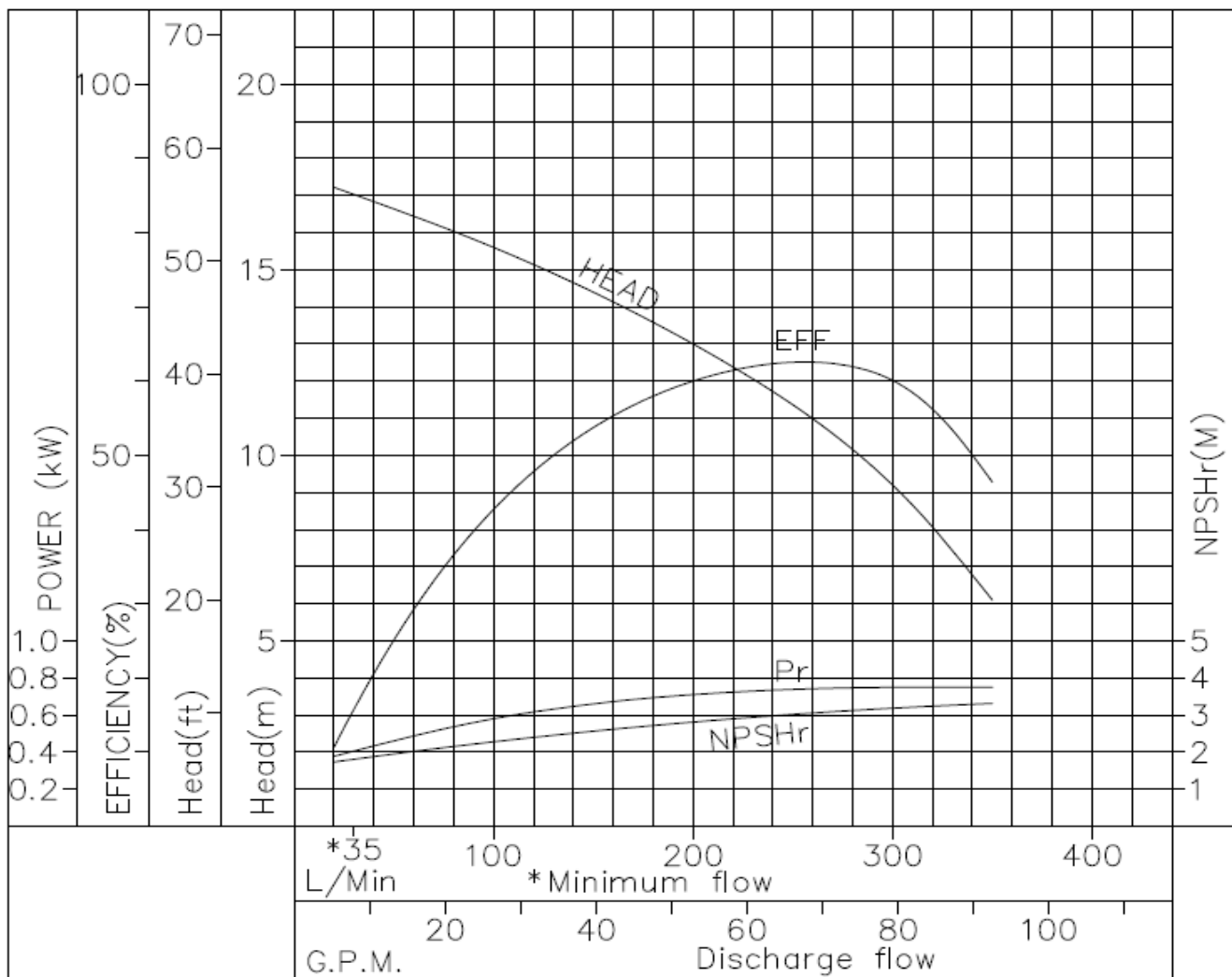

- NOTE :
1. Punto de operación nominal 11.5 m a 250 l/min
  2. Velocidad 3440 R.P.M.
  3. Rango de temperatura 0 - 60 °C Polipropileno.
  4. Potencia requerida 0.75 kW

**DIMENSIONES**

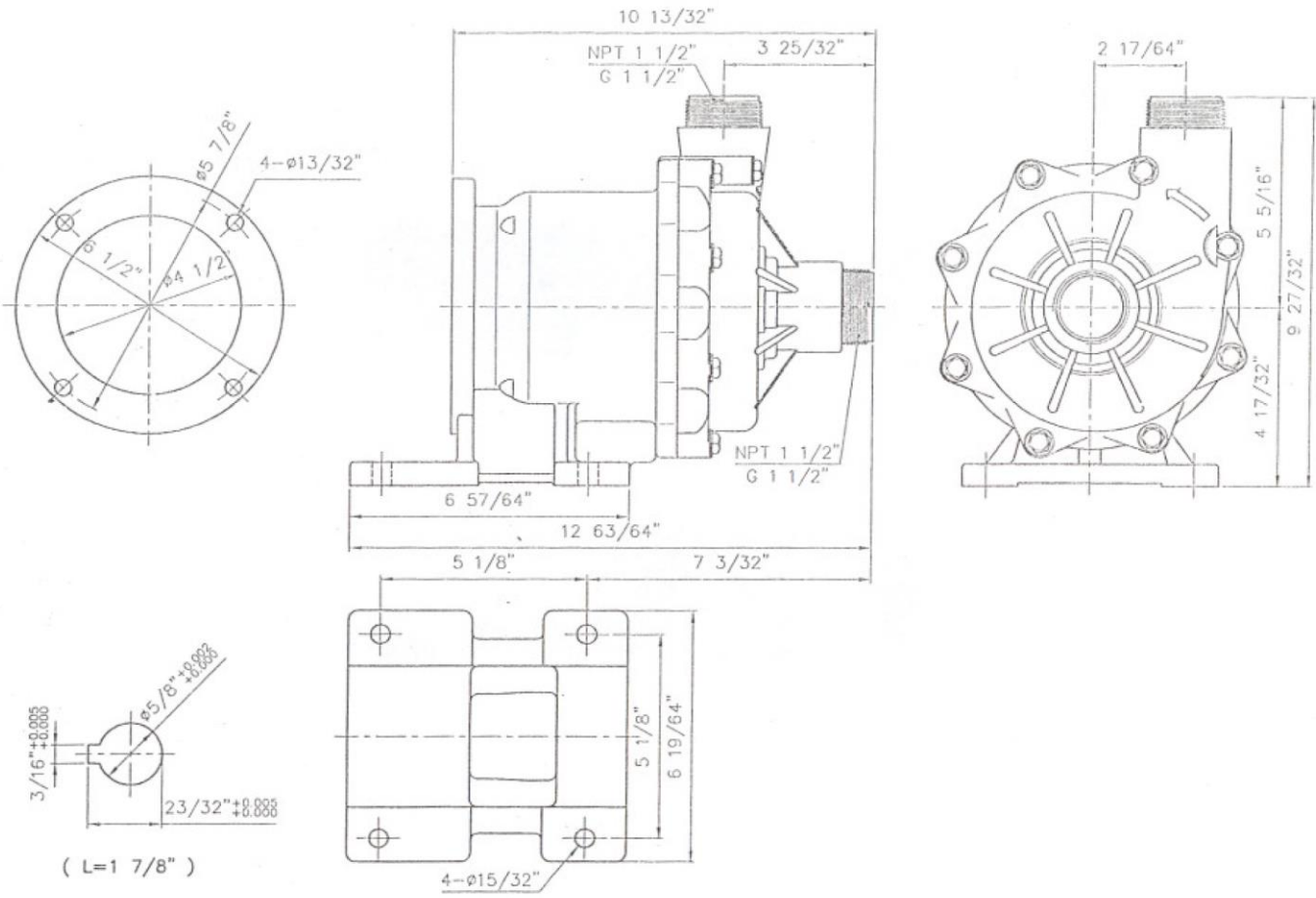

**PRODUCTOS MAV, S.A. DE C.V. / G-PUMPS**