

MODEL: NH-402PW(L)

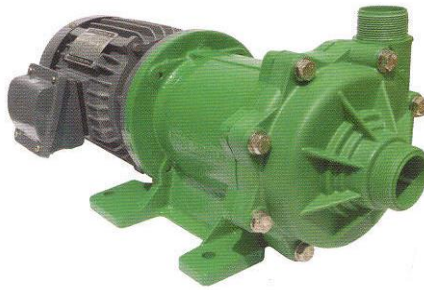

PE : 1.1

Frecuencia : 60Hz

DIÁMETRO IMPULSOR : 112 mm

	BOMBA				MOTOR
	Capacidad en descarga	Presión en descarga	CDT	Eficiencia Bomba	Potencia requerida
	L/MIN	M	M	%	kW
1	0	22.0	22	0	0.91
2	180	19.2	19.2	43.3	1.30
3	320	13.5	13.5	51.0	1.38
4	435	6.8	6.8	35.2	1.37
5	480	3.0	3.0	18.1	1.30

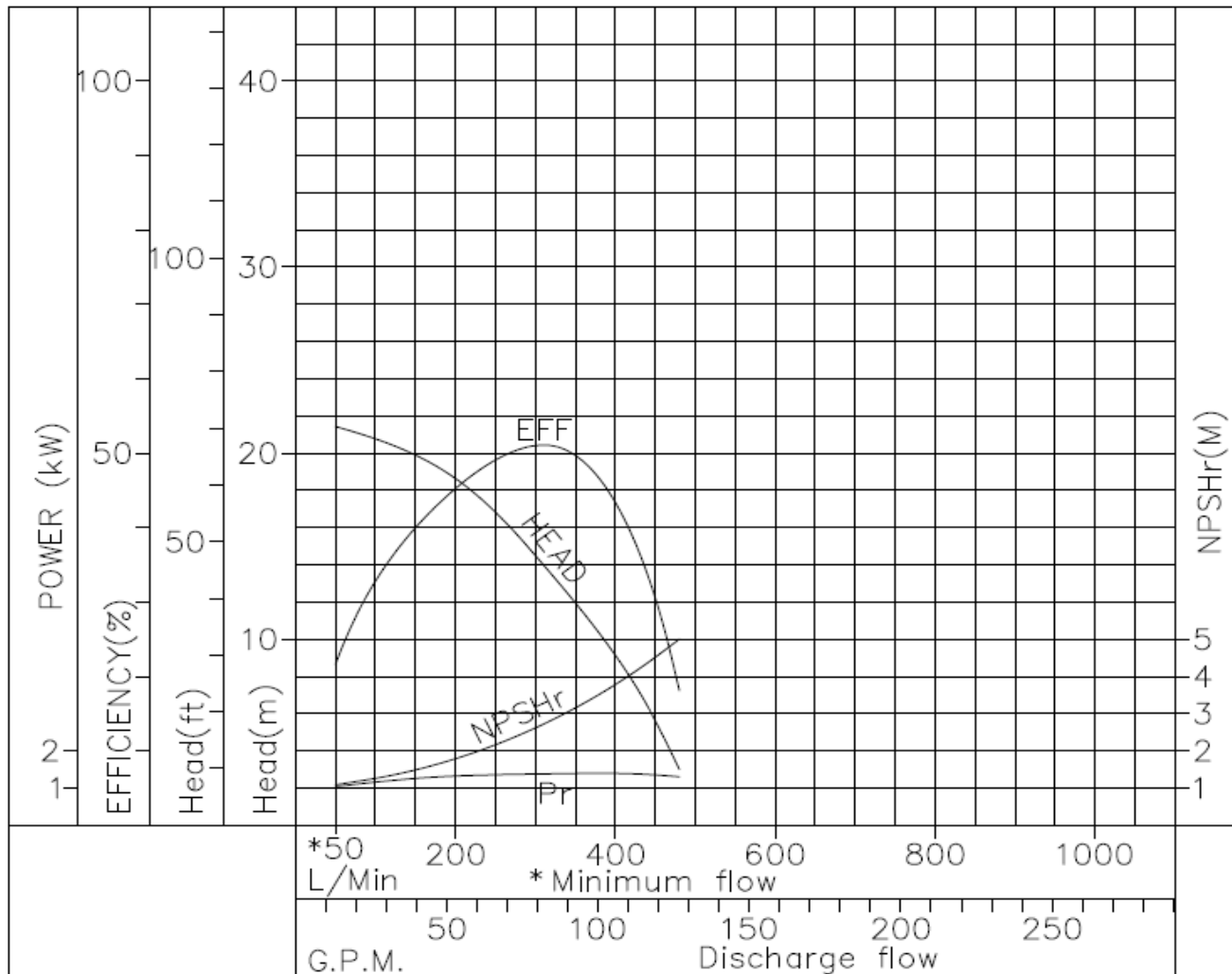

- NOTE :
- | | |
|-------------------------------|--------------------------|
| 1. Punto de operación nominal | 14 m a 300 l/min |
| 2. Velocidad | 3440 R.P.M. |
| 3. Rango de temperatura | 0 - 60 °C Polipropileno. |
| 4. Potencia requerida | 1.5 kW |

DIMENSIONES

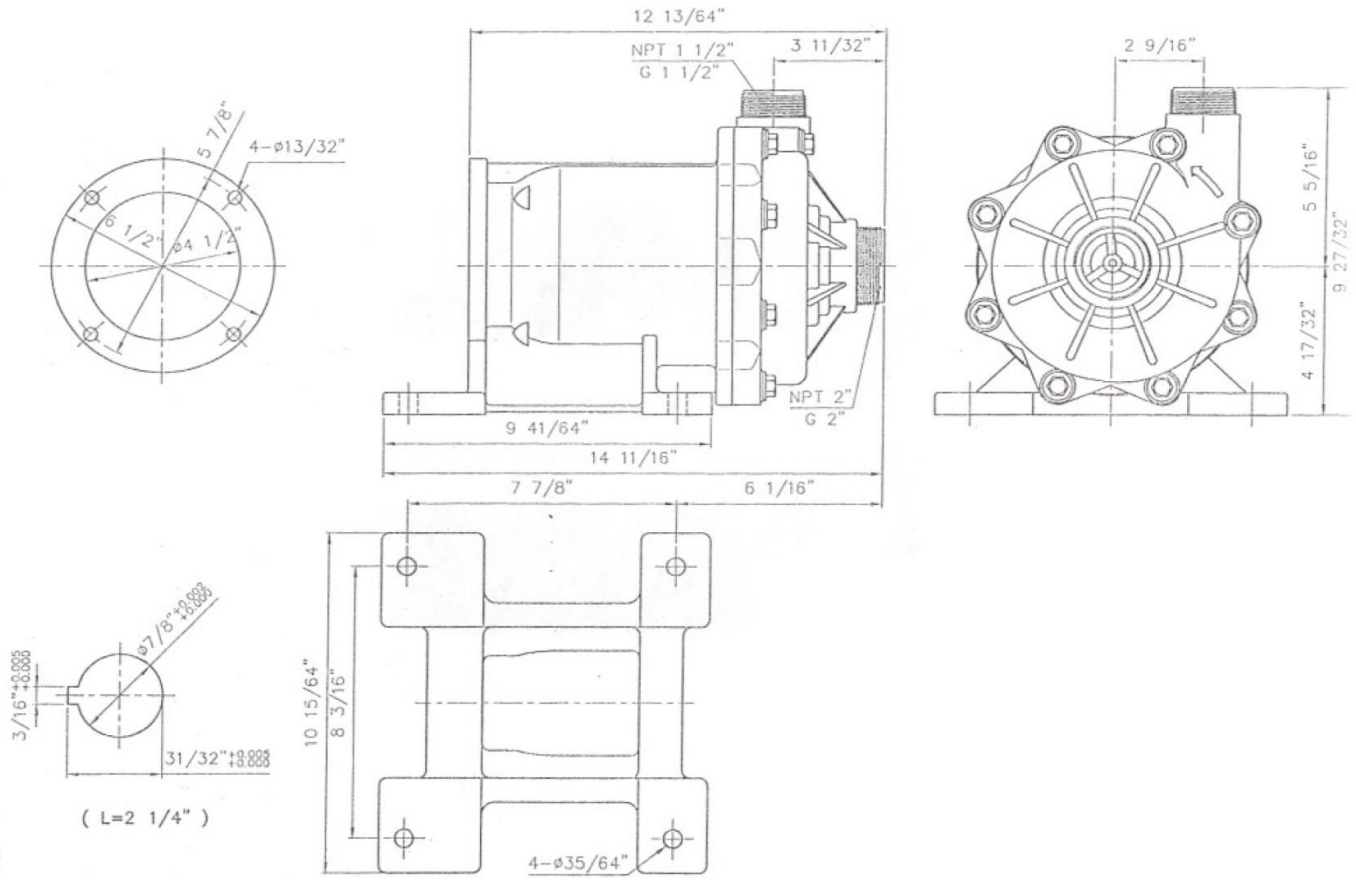

PRODUCTOS MAV, S.A. DE C.V. / G-PUMPS