

MODEL: NH-403PW(L)



PE : 1.1

Frecuencia : 60Hz

DIÁMETRO IMPULSOR : 116 mm

	BOMBA				MOTOR
	Capacidad en descarga	Presión en descarga	CDT	Eficiencia Bomba	Potencia requerida
	L/MIN	M	M	%	kW
1	0	24.5	24.5	0	1.25
2	260	20.0	20.0	47.8	1.70
3	310	18.0	18.0	47.6	1.91
4	420	7.5	7.5	26.3	1.95
5	530	3.0	3.0	14.0	1.95

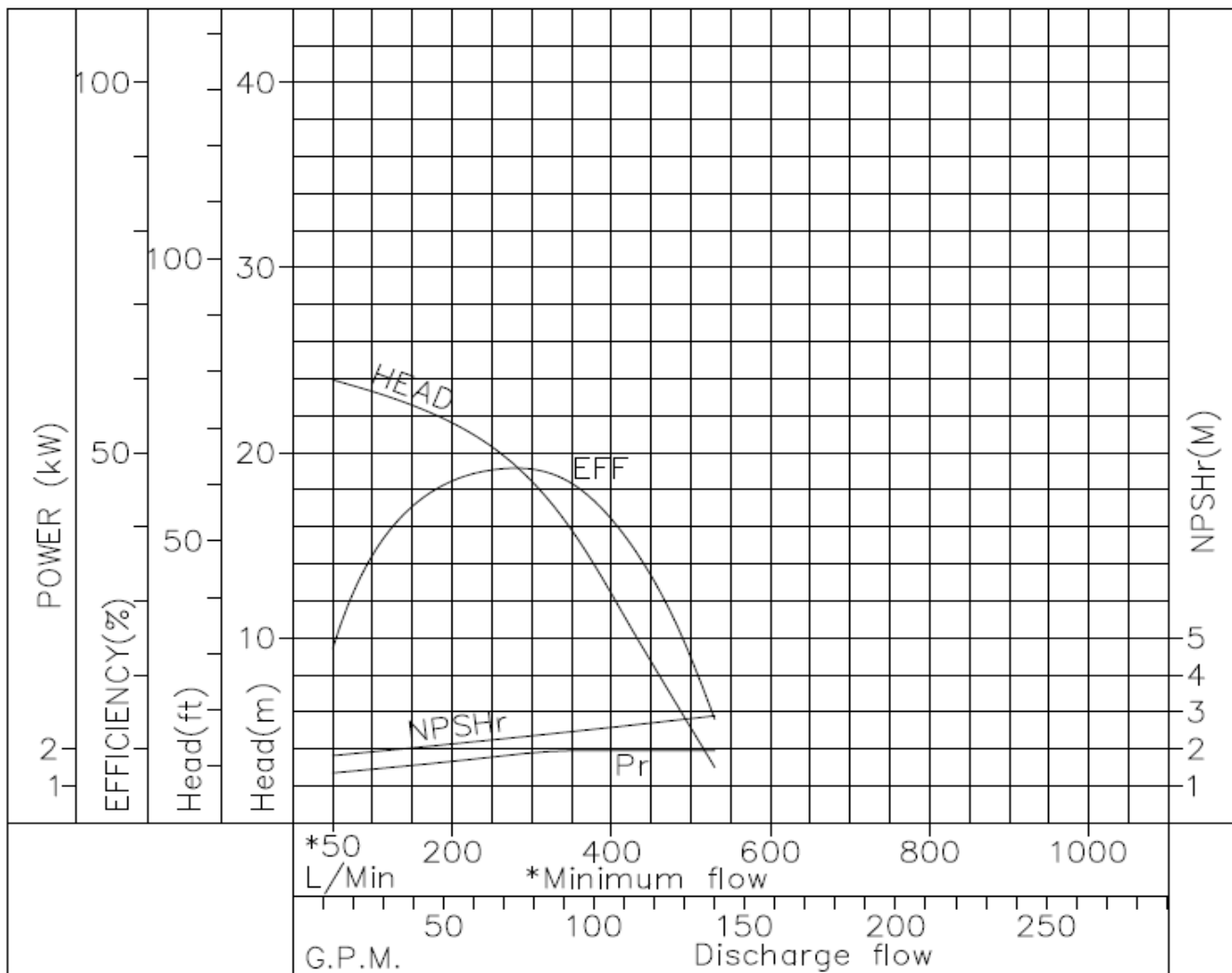

- NOTE :
- 1. Punto de operación nominal 19.0 m a 280 l/min
 - 2. Velocidad 3440 R.P.M.
 - 3. Rango de temperatura 0 - 60 °C Polipropileno.
 - 4. Potencia requerida 2.2 kW

DIMENSIONES

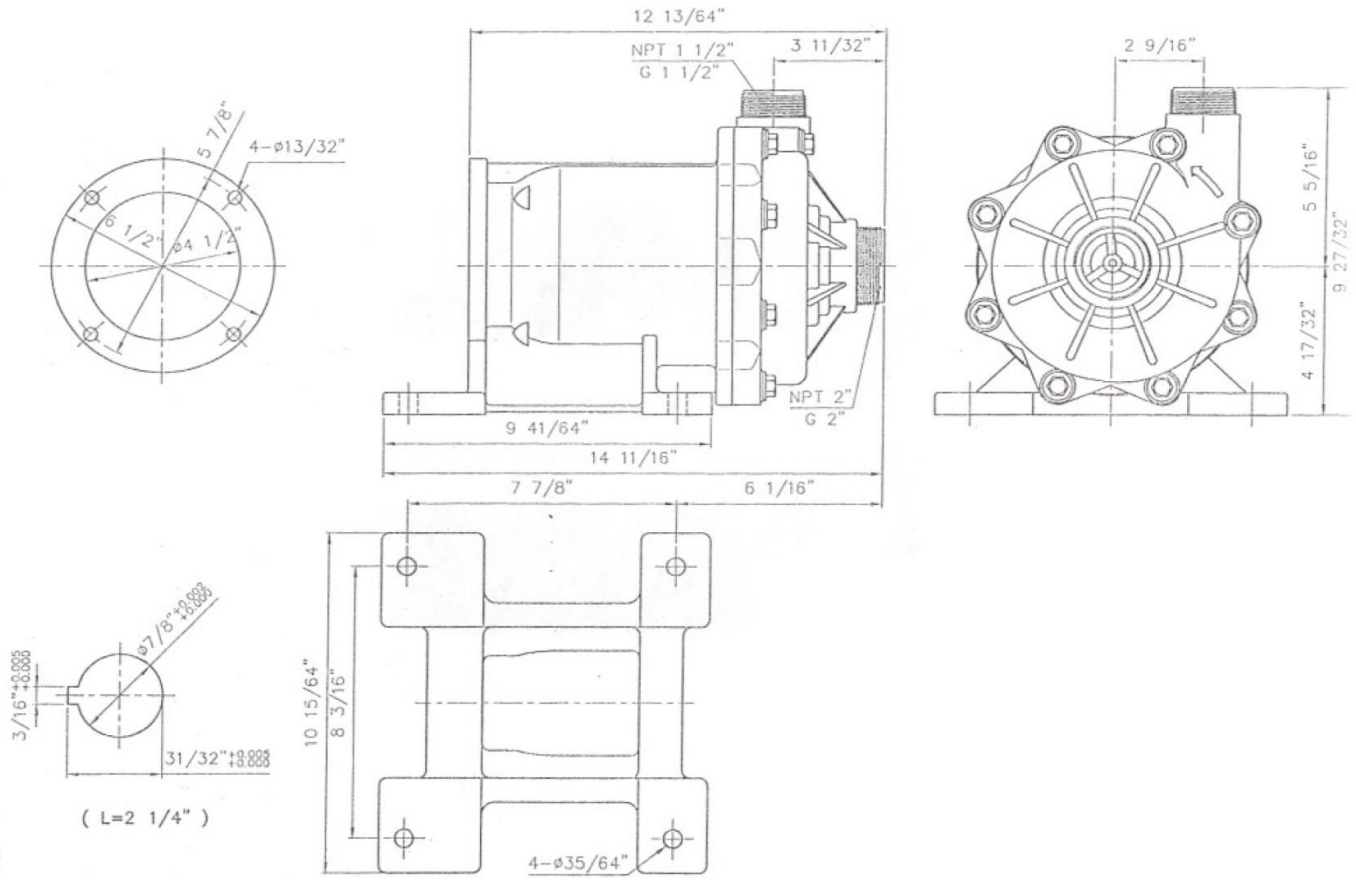

PRODUCTOS MAV, S.A. DE C.V. / G-PUMPS