

# MODEL: NH-405PW(L)

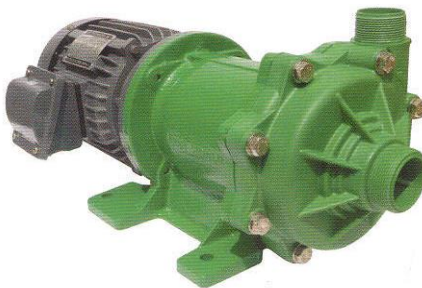

PE : 1.1

Frecuencia : 60Hz

DIÁMETRO IMPULSOR : 136 mm

BOMBA				MOTOR	
	Capacidad en descarga	Presión en descarga	CDT	Eficiencia Bomba	Potencia requerida
	L/MIN	M	M	%	kW
1	0	32.0	32.0	0	1.13
2	200	30.3	30.3	46.2	2.14
3	300	28.0	28.0	54.3	2.52
4	400	24.6	24.6	57.7	2.78
5	600	15.0	15.0	46.9	3.13

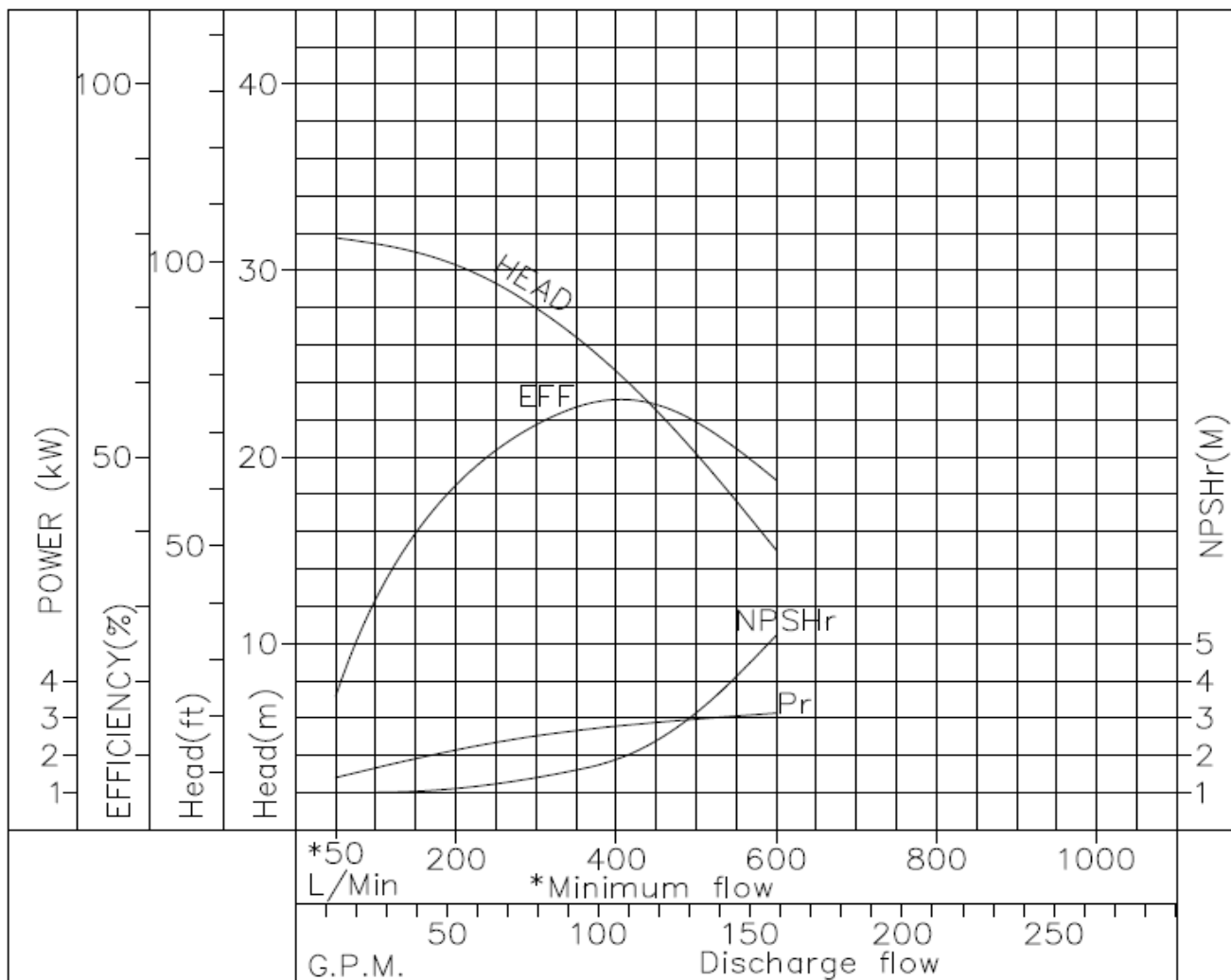

- NOTE :
- |                               |                          |
|-------------------------------|--------------------------|
| 1. Punto de operación nominal | 24 m a 420 l/min         |
| 2. Velocidad                  | 3440 R.P.M.              |
| 3. Rango de temperatura       | 0 - 60 °C Polipropileno. |
| 4. Potencia requerida         | 3.7 kW                   |

**DIMENSIONES**

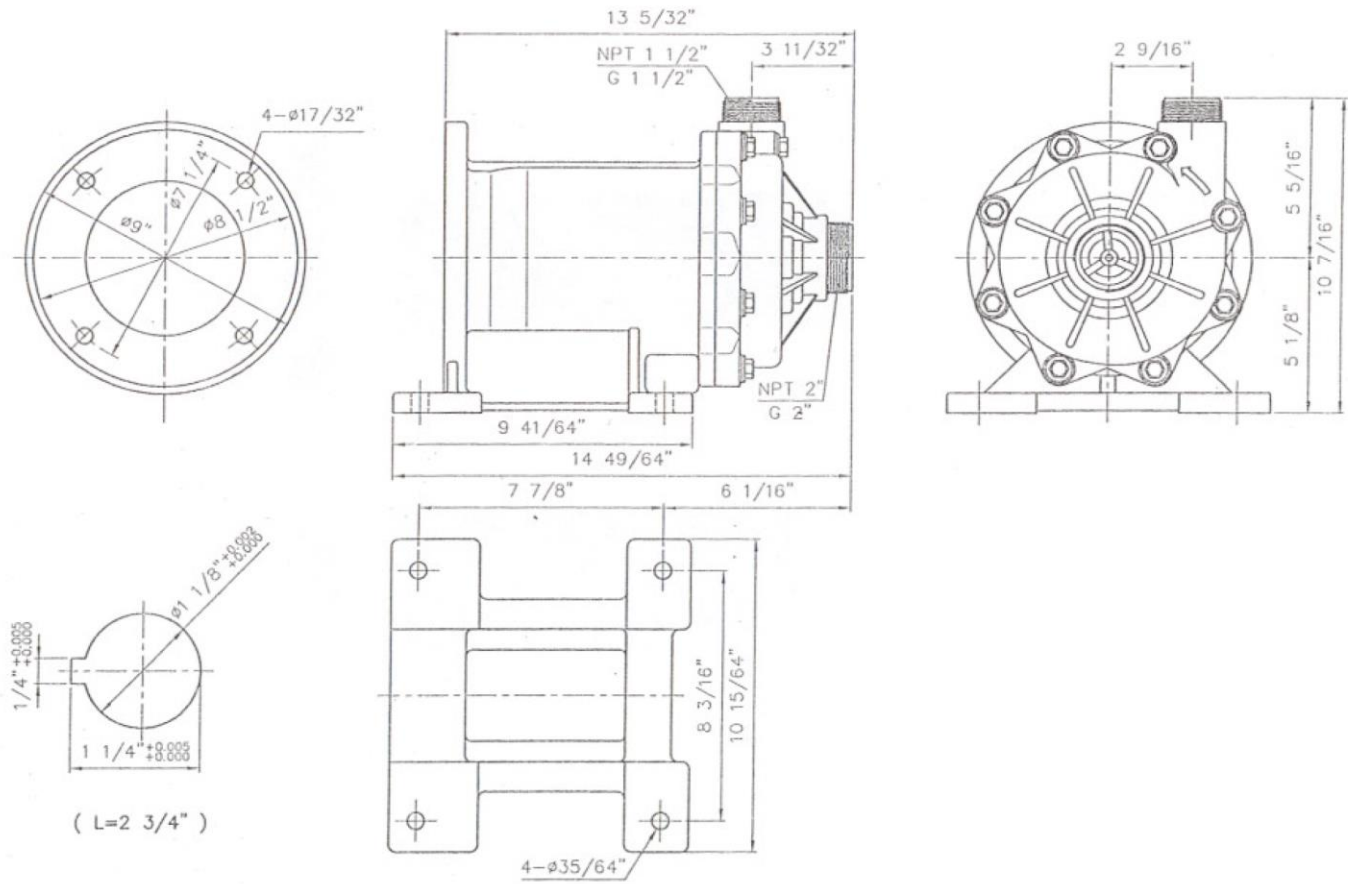

**PRODUCTOS MAV, S.A. DE C.V. / G-PUMPS**