

MODEL: NH-351PW-F(L)



PE : 1.2

Frecuencia : 60Hz

DIÁMETRO IMPULSOR : 104 mm

BOMBA				MOTOR	
	Capacidad en descarga	Presión en descarga	CDT	Eficiencia Bomba	Potencia requerida
	L/MIN	M	M	%	kW
1	0	21.8	22.4	0	0.246
2	40	20.1	20.6	31.02	0.433
3	80	17.3	27.6	39.23	0.585
4	140	11.1	11.2	37.26	0.686
5	160	8.1	8.0	29.39	0.710

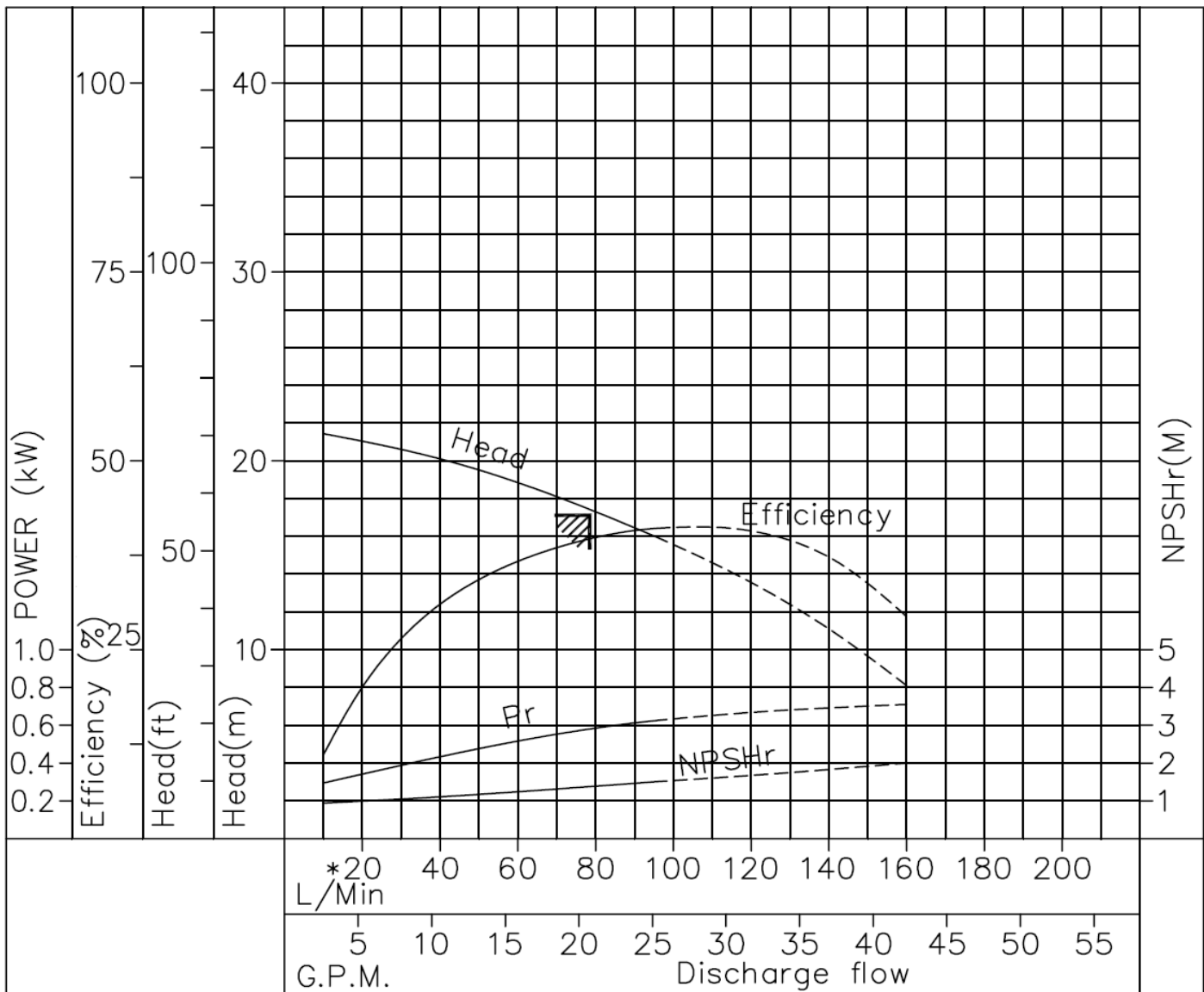

NOTA :

- | | |
|-------------------------------|-----------------|
| 1. Punto de operación nominal | 17 m a 80 l/min |
| 2. Velocidad | 3440 R.P.M. |
| 3. Rango de temperatura | 0 - 70 °C ETFE. |
| 4. Potencia requerida | 0.75 kW |

DIMENSIONES

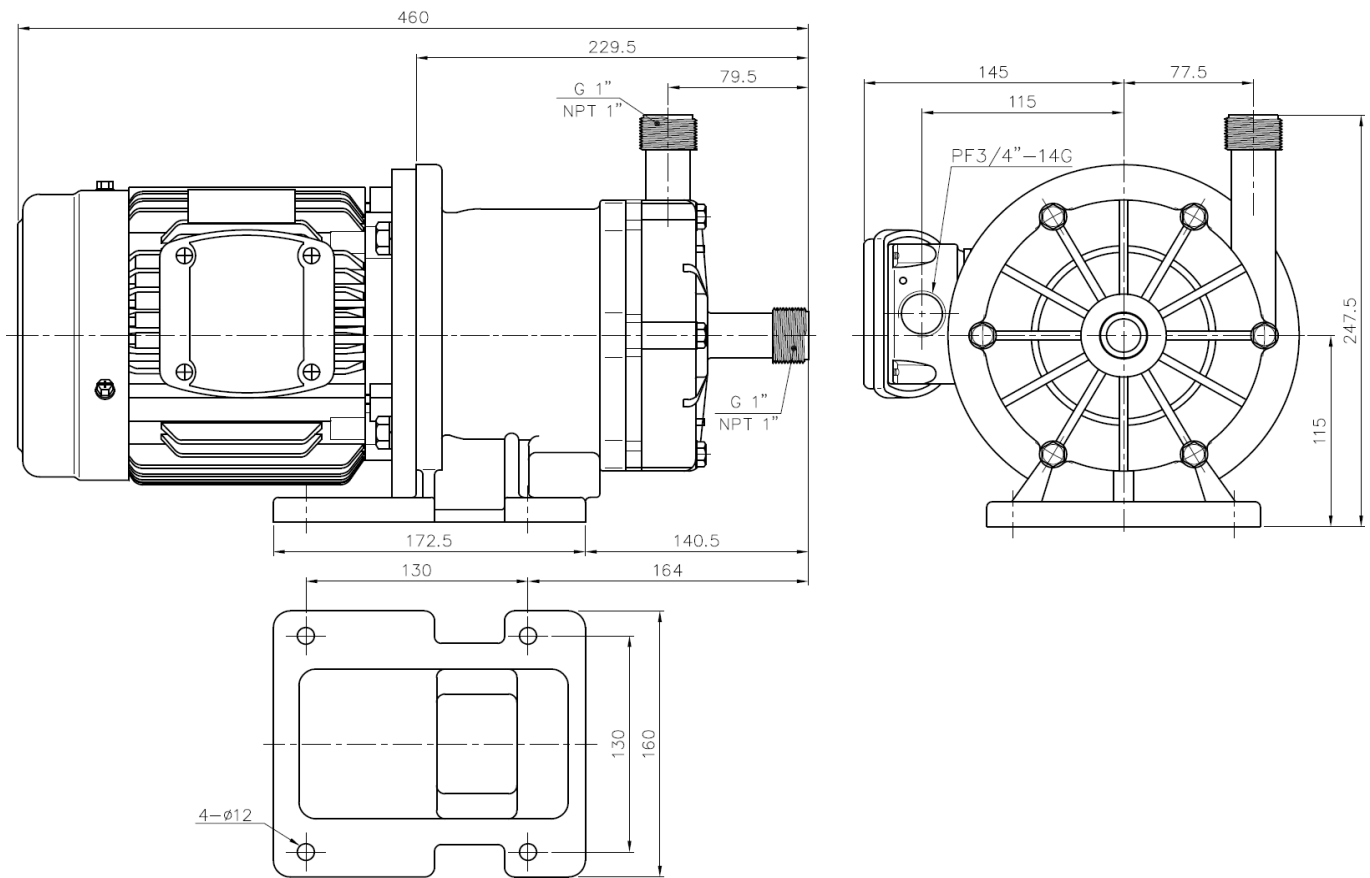

PRODUCTOS MAV, S.A. DE C.V. / G-PUMPS